

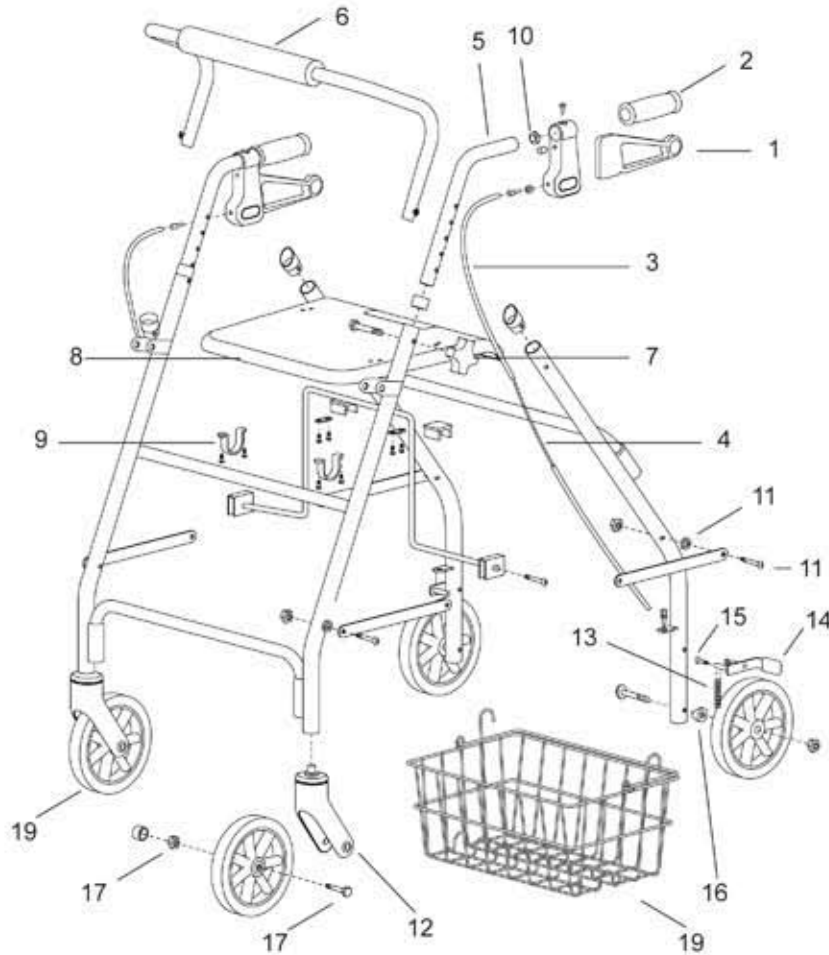

4200DX Low

No	Designation (Qty/Rollator)	UofM	Art. no
1	Brake Handle Complete Housing Plastic Cap Screw Handle with Nylon Ball Fulcrum Wheels (2 required) Fulcrum Wheel Plug (2 required)	EA	P49510
4	Wire Cable Tension Adjustment Screw	EA	P49006
10	Nylon Tube Cap	EA	P42013
5	Push Handle	EA	P42017
2	5" Rubber Handles 5" Foam Handles	PR	P42052 P42016
3	Vinyl Cable Sleeve Cover	EA	P49011
7	Star Handle and Bolt	EA	89096
6	Backrest - Removable Red Tubing Black Tubing Backrest Foam	EA EA EA	P42047L3 P42047L5 P42009
8	Plastic Seat	EA	P42055
9	Front Seat Clamp (2 required)	EA	P42041
11	Frame Bracket Bolt and Nut	EA	P42005
16	Rear Wheel Spacer	EA	P42053
	Brake Assembly		
13	Brake Spring	EA	P42035
14	L-Shaped Brake Pad	EA	P42036
15	Brake Pad Screw	EA	P42037
16	Rear Wheel Spacer	EA	P42053
	Front Wheel		
12	Front Fork with Bearing	EA	P42032
17	Front Wheel Axle & Nut	EA	P42022
18	6" Wheel with Bearings Wheel Bearing (2 required)	EA EA	P42033 H48022
19	Basket 15" x 38.1cm [L] x 10" x 25.4cm [W] x 7" x 17.8cm [D]	EA	4210



Model numbers: 4205223F & 4205225F

Parsons ADL Inc.
1986 Sideroad 15, Tottenham, ON L0G 1W0
(800) 263-1281 www.parsonsadl.com

